

## Original Article

# Laboratory Study of Effective Factors on How to Extract Carvacrol from Oliveria Decumbens Plant with the Help of Supercritical Fluid CO<sub>2</sub> and Using Ultrasound Waves



Nabil Vaeli\*

Department of Chemical Engineering, Azad University Branch of Marvdasht, Marvdasht of Shiraz, Iran



**Citation** N. Vaeli, Laboratory Study of Effective Factors on How to Extract Carvacrol from Oliveria Decumbens Plant with the Help of Supercritical Fluid CO<sub>2</sub> and Using Ultrasound Waves. *Eurasian J. Sci. Technol.*, 2022, 2(1), 34-45.

<https://doi.org/10.22034/EJST.2022.1.3>

**Article info:**

Received: 04 March 2021

Accepted: 20 June 2021

Available Online: 20 June 2021

ID: JSTR-2106-1037

Checked for Plagiarism: Yes

Checked Language: Yes

**Keywords:**

Extracritical fluid extraction, Oliveria decumbens, Ultrasound, Carvacrol, Bubble.

**ABSTRACT**

In this study, Carvacrol or Cymophenol as a combination was addressed, as the number of reports of antibiotic-resistant pathogenic microorganisms increases and considering that plant-derived products can potentially treat microbial growth in different conditions and in specific cases of the disease, very strong anti-cancer and also an antibacterial treatment of yeast infections from Oliveria decumbens plant by supercritical fluid CO<sub>2</sub> with the help of ultrasound at 150,180,210 bar and temperatures of 55, 45 and 65 °C. The compounds were examined by GC/MS device. The method is about 37% more than the distillation method with Clevenger apparatus. Also, to increase the extraction rate, C65 temperature, 180 bar pressure and 37 kHz frequency were determined as optimal conditions, in which about 26% compared with the case without ultrasound without extraction.

**Introduction**

Carvacrol or Isopropyl-2-methyl phenol-5 with the chemical formula (C<sub>6</sub>H<sub>3</sub>(CH<sub>3</sub>)(OH)C<sub>3</sub>H<sub>7</sub>) is a phenol derived from the natural monoterpene of cymene. Bacterial growth inhibitor is used as a food additive. It is an unstable volatile molecule, a flavoring agent, an antimicrobial agent, and a highly potent anticancer compound [1]. Among the properties of polyphenols are their extraordinary effect in treating cancer and reducing the risk of type 2 diabetes, as well as reducing inflammation and lowering blood

pressure for heart patients. Free radicals and reactive oxygen species and their effects on biological systems is one of the most important topics in medicine, which can irreversibly damage vital molecules such as nucleic acids, proteins, lipids and lipoproteins. Antioxidants are able to protect biological systems against these agents [2].

Due to the importance of this type of material, the method of extraction and its mechanism in such a way that it is not damaged by heat or chemicals in the extraction steps are considered. The methods seem to have high efficiency compared with other methods, but in the purification stages of the active substances

\*Corresponding Author: Nabil Vaeli (nabilvaeli@miau.ac.ir)

extracted by them, they are subjected to high heat, which causes the destruction of active substances sensitive to temperature, and also concentration by chemicals, leaving these chemicals after the steps. Concentration with the extracted material reduces the purity of the active ingredients. Therefore, various methods are used to extract the active pharmaceutical ingredients. There are many advantages, including availability, low cost and no pollution in the environment. It also has a number of limitations. One of the main problems is the kinetics when using supercritical fluid as a solvent for slow process extraction. The solubility of many materials in supercritical fluids is usually less than that used in conventional extraction processes, so mass transfer speed will be slower. One traditional way to speed up the separation and extraction process is to use the tools of a mechanical excitation system. Another is to use a high intensity ultrasonic process. The use of ultrasonic force in supercritical fluid sections shows the good use of this potential energy. One of the most important and essential applications of ultrasonic power in extraction is in the food and chemical industries, in which various processes extraction processes have been mainly focused on plant compounds. Plants have a wide range of bioactive compounds such as lipids, phytochemicals, flavors, aromas or pigments that are widely used in food. Interest in these compounds has increased the need to improve extraction methods that can obtain the maximum possible amount of bioactive substances in a short time and at a low cost. Extraction of antioxidants such as anthocyanin, flavones or phenolic acids has been specifically examined. The special properties of polyphenols have been considered by the health food industry, which increases the antioxidant activity and biological benefits of their foods [3]. This type of extraction is based on natural additives such as soy flavor, capsaicinoids [5] and dyes [6] have also been concentrated. In addition, this type of extraction can be used to remove undesirable compounds in foods, such as some aromatic compounds [7].

There are many extraction techniques such as massage, digestion, induction, diffusion, continuous hot extraction, reverse flow extraction, extracurricular fluid extraction, microwave extraction, phytochemical processes or extra-wave extraction [8]. The main differences between these techniques are related to the design of the reactors, the solvent used, the time and temperature of the processes, or the use of new technologies. Conventional liquid-solid extraction techniques are very laborious and time consuming and often require large volumes of organic solvents [9]. Today, there is a growing tendency to use more environmentally friendly solvents such as water and alcohol mixtures, which leads to increasing costs and decreasing material obtained from extraction. Therefore, there is a great interest in creating more efficient extraction methods.

By increasing the pressure and temperature, the extra critical stage can be achieved, which creates a situation where no distinction is made between gas and liquid [10]. The density of extracorporeal fluids is exactly between gas and liquid and therefore its solubility is higher than gas. Their transfer properties, such as lower viscosity and greater dispersion than liquid solvents, result in more extractive material being obtained by penetrating porous solids more efficiently than liquid solvents [11]. The most common fluid used to extract extracorporeal fluid is carbon dioxide due to its low temperature and pressure, and its quasi-static state. In fact, the extracted organic compounds are easily separated because carbon dioxide is at atmospheric pressure. It is a gas and therefore can be recycled.

Ultrasonic extraction technique has been widely used in the last two decades as an effective extraction method in the food and pharmaceutical industries. The number of articles published on this subject has grown exponentially over the last three decades. Depending on the use of this technique with different intensities, different effects also occur. In the use of this low-intensity technique, resistance to external and possibly internal mass transfer is affected. However, the structure of the product remains largely unchanged. In use with moderate intensities,

the product structure may be affected and therefore the resistance to internal mass transfer is affected. If the power of the ultrasound waves increases again, cell degradation may occur.

Today, ultrasound technique is a powerful tool in extraction processes and even the reference of some extraction technologies is being developed [13]. Extraction by ultrasound, for example in the extraction of polyphenols from plant tissues [14], protein, sugar [15] and starch [16] from cereals and legumes, oils [17], flavoring compounds [18] from mint and lavender, has been used. Extraction increases the efficiency and speed of extraction and reduces the required temperature, allowing solvents to be retained, and cause the solubility of the target compounds [19]. A significant increase in local temperature increases the solubility of the analytes, as is the case with lipids, in the solvent and facilitates their diffusion from the sample matrix to the outer region. On the other hand, the solvent facilitates the sample matrix and the transfer of compounds. In addition, the collapse of pore-forming bubbles can hit the surface of the solid matrix and decompose the cell [20]. As a result of these effects, less extraction time, unlike traditional extraction processes, are needed. Accordingly, Roland Gutierrez et al. [21]

showed that to extract valuable compounds from aromatic plants and flowers, the use of ultrasonic extraction techniques is between 50 and 51 times faster than the method. Traditional extraction by steam distillation is also between 0 and 2 times faster than the extracorporeal extraction method of water. One of the major drawbacks of ultrasonic extraction technique compared with extracorporeal extraction of carbon dioxide is the inevitable use of organic solvents in some cases. However, the equipment used is simpler and the overall cost is lower. In this research for the first time, an ultrasonic bath system with variable frequencies of 37 and 80 kHz and a power of 50 to 310 watts has been used in the supercritical extraction system to increase the extraction of Carvacrol from *Oliveria decumbens*. This causes the amount of bubbling within the cavities in the pores between the particles to increase and the growth of the cavitation bubbles to increase to its maximum [22-25].

### Materials and Methods

For this research, about 200 grams of plants of *Oliveria decumbens* were collected from the plains around Kazerun. The CO<sub>2</sub> used in this research was 99% pure gas produced by the German company Merck [26].



**Figure 1** Picture of *Oliveria decumbens*

### Extraction of Distillation Method with Cleverger System

At this stage, the amount of 5 g of dried *Oliveria decumbens* was obtained as a uniform powder and with 50 ml of distilled water was introduced into a cloning device with a volume

of 200 ml and heated to a temperature range of 110 °C. The test time was about 45 minutes. GC/ MS was scanned and the percentage of plant compounds was determined (Table 1).

The gas chromatographic graph of the extract from the cloning device can be seen in Figure 2.

**Table 1** GC / MS analysis of compounds in *Oliveria decumbens* extracted by distillation with Clevenger

No.	Scanned component of the <i>Oliveria decumbens</i> plant	%GC/MS Analysis Clevenger
1	Cyclotrisiloxane, hex methyl- (CAS)	2.941
2	1H-Imidazole, 4,5-dihydro-2-methyl-	-
3	Benzene, 1,3-dimethyl-	3.504
4	2,2-dimethyl-3-methylene-bicyclo [2.2.1] heptane	6.089
5	Cyclotetrasiloxane, octamethyl-	5.360
6	Cyclobutane	-
7	Benzene, 1-methyl-4-(1-methylethyl)-	5.026
8	Octanoic acid	-
9	Methoxyacetonitrile	-
10	Benzoxazol, 2,3-dihydro-2-thioxo-3-diallylaminomethyl-	3.56
11	1-Azabicyclo [3.1.0] hexane	4.382
12	Hexane, 2,3,5-trimethyl-	2.895
13	Cyclohexasiloxane, dodecamethyl-	2.091
14	Carvacrol	-
15	Phenol, 5-methyl-2-(1-methylethyl)-	23.670
16	Oxalic acid, allyl nonyl ester	3.809
17	Nonadecanoic acid	-
18	dimethyl-3(2H)-Benzofuranone, 7-hydroxy-2,2-dimethyl-	4.006

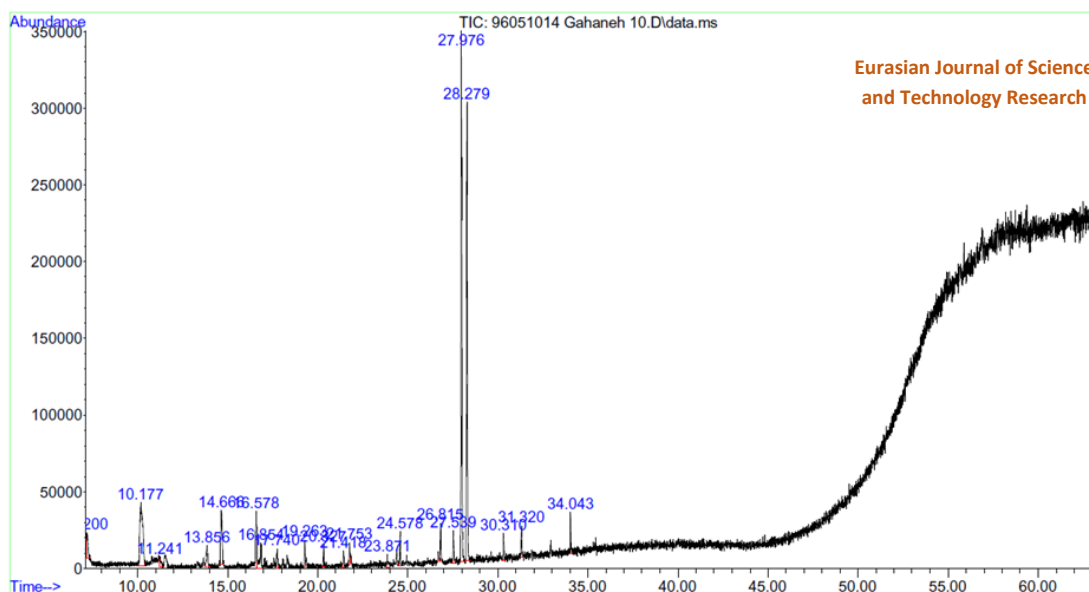
**Figure 2** Gas chromatographic analysis of the extract extracted from the Clevenger apparatus

### *Supercritical Extraction System with the Help of Ultrasonic Waves*

As shown in figure 3, the system consists of three main parts (CO<sub>2</sub> gas storage tank) from which the exhaust gas from the tank (pressure between 70-80 bar) enters the cooling system (with a temperature of -20) after condensation. The holding tank enters has a piston pump to compress liquefied gas and increase the gas pressure to provide supercritical pressure

(pressure change from 150 to 210 bar extraction tube made of double-walled stainless steel (height = 23 cm, inner diameter by 2.8 cm and outer diameter by 3.5 cm) which has a pressure tolerance threshold of up to 600 bar. To provide supercritical temperature, the temperature of the outer wall of the cell is extracted by circulating water by means of a heater; the temperature is heated to 45 to 65 °C. For the sonicator system, the extraction vessel was placed in an ultrasound bath (ELMA brand)

made in Germany with a power of 310 watts, which is capable of changing the frequency of

37 to 80 kHz radar. Escape is embedded [27-29].

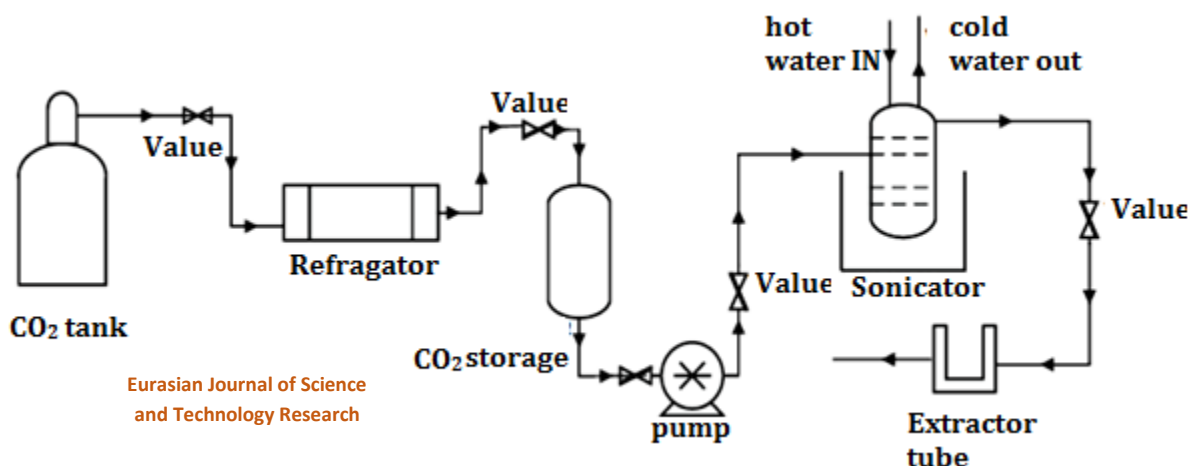

**Figure 3** Diagram of a supercritical extraction device

### Extraction with the Help of Supercritical Fluid System

Extraction was performed using a supercritical fluid extraction system in two stages: (I) static with pure CO<sub>2</sub>, flow rate 6 ml / min at constant pressure 180 bar temperature 65 °C at 37 kHz for 40 minutes, until contact between samples and the supercritical solvent should be done completely; (II) the dynamic step performed to extract polyphenols in 15-25 minutes at 180 bar pressure and 65 °C and 37

kHz frequency with the help of supercritical fluid CO<sub>2</sub>. Due to the high volatility of the sample extracted from the system, dichloromethane solvent is used after dissolution. The volatile substance in the solvent that is placed in the ice container is evaporated by separating the ice from dichloromethane and the active substance remains in the container. The conditions considered for the supercritical extraction of polyphenols and antioxidants are according to Table 2 [30-32].

**Table 2** Laboratory conditions for extraction of polyphenols and antioxidants from *Oliveria decumbens*

Pressure (bar)	Temperature (°C)	Frequency (kHz)	Time (min)
150	45	0	15
180	55	37	20
210	65	80	25

To determine the test steps in this research, MINITAB software, Taguchi method was used. In this design, 4 factors of pressure, temperature, frequency and particle size are considered as variable parameters and three levels are determined for each. A total of 21 test steps were designed by this software. After performing the experiments by supercritical extraction with the help of ultrasound (USC-

CO<sub>2</sub>) and without ultrasound (SC-CO<sub>2</sub>), the materials extracted from this plant were scanned by GC/MS and the results of its compounds is reported in table 3 [32-34].

Figures 4 and 5 show the gas chromatographic diagrams of the extracted extracts using SC-CO<sub>2</sub> and USC-CO<sub>2</sub>.

**Table 3.** GC / MS analysis of compounds in *Oliveria decumbens* extracted by supercritical method in SC-CO<sub>2</sub> and USC-CO<sub>2</sub> modes

No.	Scanned component of the <i>Oliveria decumbens</i> plant by GC/MS	%GC/MS Analysis SC-CO <sub>2</sub>	%GC/MS Analysis USC-CO <sub>2</sub>
1	Cyclotrisiloxane, hexamethyl- (CAS)	2.334	2.613
2	1 <i>H</i> -Imidazole, 4,5-dihydro-2-methyl-	-	0.905
3	Benzene, 1,3-dimethyl-	1.79	2.34
4	2,2-dimethyl-3-methylene-bicyclo [2.2.1]heptane	3.843	4.562
5	Cyclotetrasiloxane, octamethyl-	2.385	3.205
6	Cyclobutane	-	1.486
7	Benzene, 1-methyl-4-(1-methylethyl)-	-	1.148
8	Octanoic acid	23.63	25.371
9	Methoxyacetonitrile	-	0.9
10	Benzoxazol, 2,3-dihydro-2-thioxo-3-diallylaminomethyl-	0.944	1.098
11	1-Azabicyclo[3.1.0]hexane	0.971	2.136
12	Hexane, 2,3,5-trimethyl-	1.431	1.802
13	Cyclohexasiloxane, dodecamethyl-	1.738	2.091
14	Carvacrol	23.754	29.625
15	Phenol, 5-methyl-2-(1-methylethyl)-	21.988	26.583
16	Oxalic acid, allyl nonyl ester	-	1.562
17	Nonadecanoic acid	25.009	28.47
18	3(2 <i>H</i> )-Benzofuranone, 7-hydroxy-2,2-dimethyl-	1.965	2.703

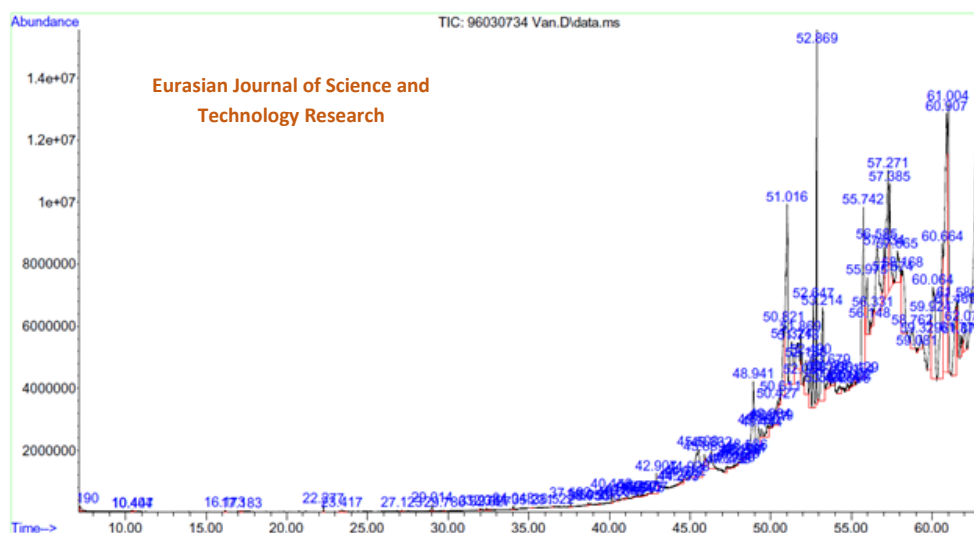
**Figure 4** Gas chromatographic analysis of the extracted extract by SC-CO<sub>2</sub> method



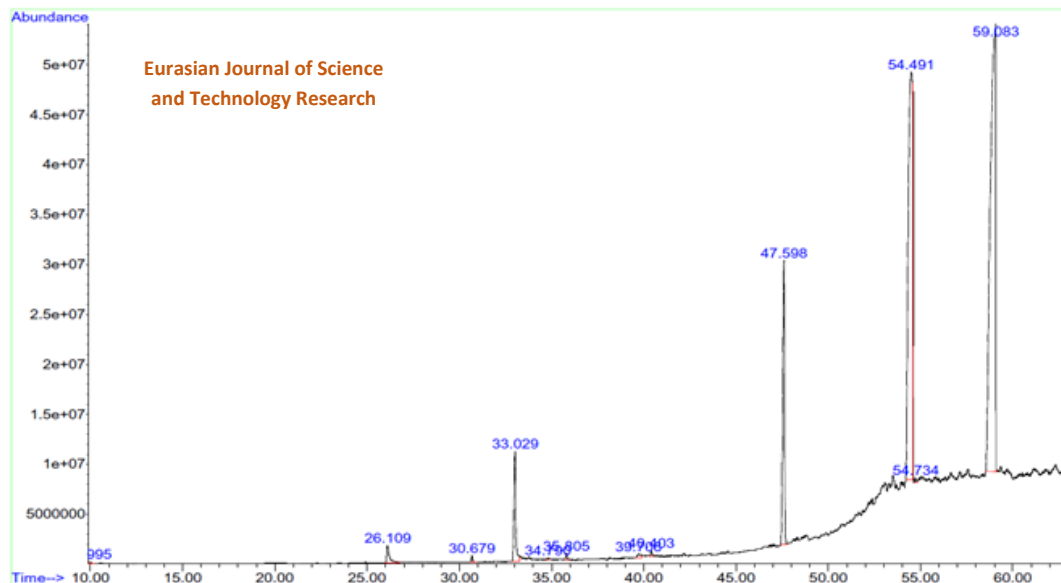

**Figure 5** Gas chromatographic analysis of the extracted extract by USC-CO<sub>2</sub>

Among the compounds extracted from *Oliveria decumbens*, the four substances that have the highest number of medicinal properties and the highest percentage of the compound are Nonadecanoic acid, Phenol, 5-methyl-2- (1-methylethyl), Carvacrol and Octanoic acid. It is effective in extracting these compounds in this research [34-36].

## Results

In this study, extraction was investigated in three ways: Extraction with Clevenger, supercritical extraction without the help of ultrasonic waves and extra critical extraction with the help of ultrasonic waves, which showed that in extraction using Clevenger due to the high temperature range of distillation (Above 100 °C). Most of the useful temperature-sensitive medicinal extracts are destroyed and not extracted, so supercritical extraction is important due to the low temperature range, which is then compared with USC-CO<sub>2</sub> and USC-CO<sub>2</sub> due to the importance of extracted antioxidants becomes. The results of the study of the effect of ultrasonic waves showed that after studying the effect of ultrasonic waves on the parameters of pressure, temperature and particle size, it was revealed that the phenomenon of foaming bubbles caused by ultrasonic waves increases efficiency in temperatures, pressures and particle size. The

effect of frequency showed that the frequency of 37 kHz compared to the frequency of 80 kHz in terms of stronger shocks to the solid bed increases the size of the bubbles created in the pores of the solid particle and also increases turbulence between solvent and solvent, which results in more active material leaving the solid particle pores and increasing extraction.

## Discussion

In this section, the effect of effective parameters on the extraction rate in the supercritical method was investigated, the most important of which are pressure, temperature, frequency and particle size.

### *Effect of Pressure*

According to Figure 6, in the SC-CO<sub>2</sub> diagram, the efficiency increases with increasing pressure. The reason for this increase in efficiency can be explained by the fact that increasing the pressure increases the density and consequently the density increases the solubility, so the extraction efficiency increases. On the other hand, increasing the pressure increases the neighboring number, which is the number of solvent molecules surrounding the solid particle. As the neighboring number increases, the amount of solvent-solvent contact increases, resulting in more solubility

and increased efficiency, but in the diagram, USC-CO<sub>2</sub> increases to a bar pressure of 180 and then decreases. The reason for this is that initially increasing the pressure, for the reasons mentioned above, will increase the efficiency. This increase in efficiency to the optimal bar pressure. 180 will continue, but because ultrasound waves are present in this process and these waves cause holes in the solid bed, they also create bubbles inside the pores of the

solid bed pores, trapped air molecules. Increasing these holes causes effective materials to leave the solid. On the other hand, the creation of these bubbles, which burst due to the increase in pressure, causes the active substances to come out of the solid bed, but the growth of these bubbles and their bursting to the optimum pressure of 180 bar is well done by increasing the pressure to more than 180 bar.

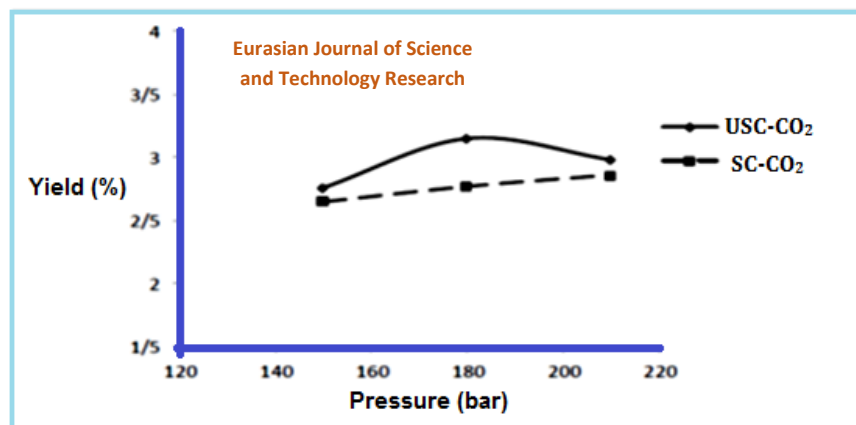

**Figure 6** Effect of extraction pressure on the yield of *Oliveria decumbens* extract at C65 temperature and particle size of 1/mm

### Effects

Supercritical extraction against different temperature changes has different modes. In different studies, it has been found that the maximum amount of product obtained from extraction at completely different temperatures is obtained for each of the compounds. In general, increasing the extraction temperature increases the mass transfer. However, increasing the temperature causes less production of cavitation energy conversion due to decreasing surface tension and increasing vapor pressure. In Figure 7 in the SC-CO<sub>2</sub> mode we see an upward trend in efficiency up to 55 °C due to the increase in vapor pressure. Consequently, it will increase the solubility, but at the same time, increasing the temperature will also reduce the density, which will reduce the solubility, and will reduce the efficiency at temperatures above 55. Therefore, in the case of increasing the temperature, 55 is one temperature. It is optimal when the solubility reaches its maximum value. In the USC-CO<sub>2</sub> diagram, we see that the efficiency is up to 65

°C. The reason for this is that in this process, the presence of ultrasound waves around the solid bed and its successive shocks cause air molecules trapped in the pores of the solid particle bed (air molecules may be trapped in the pores of the plant during abrasion and crushing) and bubbles that burst further cause the solvent to dissolve and the active material to exit the particle pores. Solid also increases the contact surface between a solid particle and a fluid Fu AH becomes a crisis that will result in increased extraction efficiency. Increasing the temperature in this process causes these bubbles to burst, so with increasing temperature, the bursting of these bubbles occurs more quickly, so the extracted material becomes more.



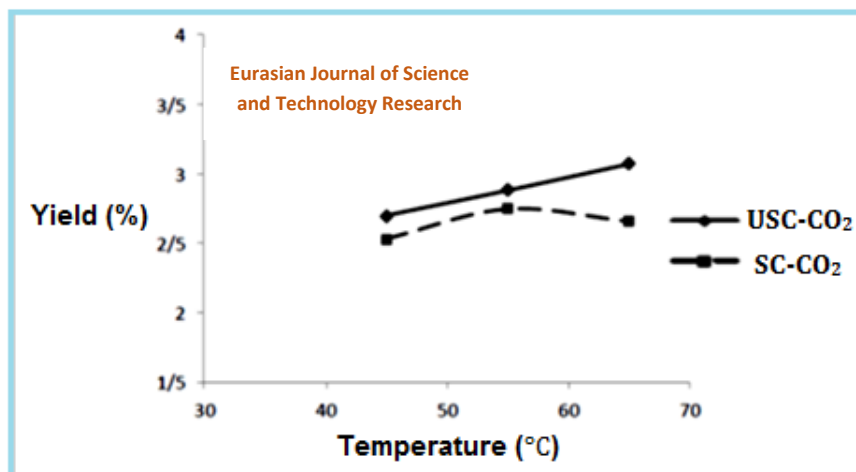
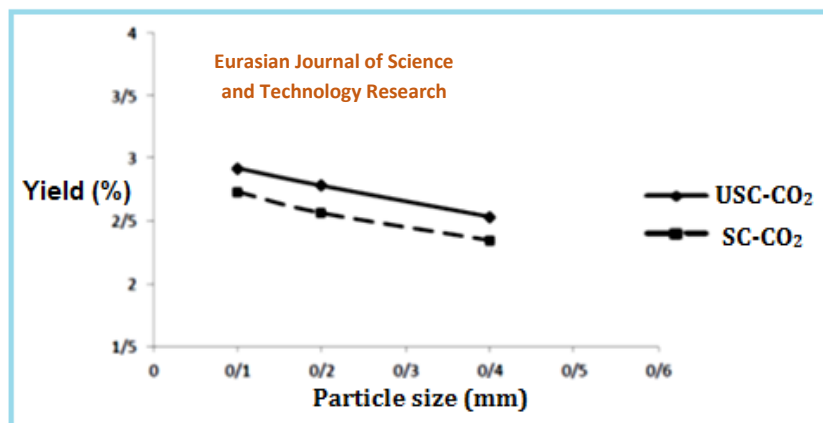

**Figure 7** Effect of extraction temperature on the yield of *Oliveria decumbens* extract at 180 bar and particle size of /1 mm

#### Particle Size Effect

It is known that the smaller the sample particle size, the higher the recovery percentage, but usually an optimal limit should be considered. The dynamic extraction process consists of two parts: The first part is the transfer of the solute to the fluid mass (and away from the sample chemical tissue) where the rate of mass transfer depends on the rate of penetration into the fluid mass. The second part, which is more important than the first part, is the penetration of the sample from the chemical tissue to its surface. In Figure 8, in the SC-CO<sub>2</sub> state where ultrasound waves are not present, as can be seen, the larger the particle diameter, the siren return returns. When the

solid particle is small in size (about 0.1) due to this change of state, the holes created on the solid bed increase and the holes and the pores of the active material exit from the inside of the particle to the outside during the penetration of supercritical fluid in it. As mentioned, this causes more soluble transfer to the fluid mass, which results in increased mass transfer, but in the USC-CO<sub>2</sub> mode, the presence of ultrasonic waves and the shocks generated by them cause the active material to be affected by these oscillations and shocks from inside the pores. The holes created in the solid bed are thrown out, so the smaller the particle, the greater its effect against ultrasound and the more effective material is released out of the solid bed, which will result in increased efficiency [36-38].

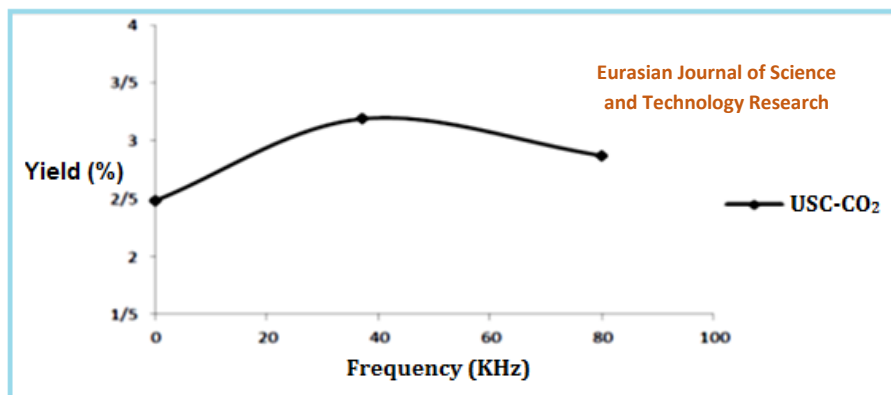

**Figure 8** Effect of particle size on the yield of *Oliveria decumbens* extract at 180 bar and 65 °C

### Frequency Effect

It is clear that the lower the frequency, the larger the cavitation bubbles. Therefore, lower frequencies of powerful ultrasonic waves (around 37 kHz) are the most severe in bubble bursts and are therefore more efficient for extraction processes. As long as the extraction system has a heterogeneous and complex environment with porosity, the effect that bubble size has on extraction efficiency must be considered. The effect of frequency may be related not only to the size of the pore-forming bubbles, but also to its effect on the internal and external resistance of the mass transfer. In Figure 9, at 37 kHz, we see the highest efficiency, after which we see the downward

trend of the graph towards the frequency of 80 kHz. Which one improves the penetration of the solvent and mass transfer? On the other hand, these shocks cause porosity and penetration of the solvent and increase the contact surface. Also, at this frequency, the bubbles created in the pores of the solid matrix are larger. More and more effective substances are removed from the pores at 80 kHz frequency with less power but faster velocity. This causes the cavitation bubbles not to reach their full growth and burst before they enlarge. Reducing the amount of mixing between solvent and soluble and reducing the release of effective materials from the pore of the solid particle will result in reduced extraction efficiency [39-41].



**Figure 9** Effect of frequency on the yield of *Oliveria decumbens* extract at 180 bar and 65 °C

### Conclusion

In this study, the mechanism of effect of effective factors on the extraction of polyphenols and antioxidants of *Oliveria decumbens* plant at pressures of 150, 180 and 210 bar and temperatures of 45, 65 and 65 °C and frequencies of 37 and 80 kHz was investigated by extraction with a clearing device and supercritical extraction device by ultrasound. Although it seems to have a higher yield than supercritical extraction, its high temperature range during distillation destroys the very important antioxidants and polyphenols of *Oliveria decumbens* such as Nonadecanoic acid, Carvacrol and Octanoic acid. Also, the effect of thermodynamic factors on extraction is shown. It was shown that in

USC-CO<sub>2</sub> mode, the optimum pressure of 180 bar and the optimum temperature of 65 degrees had the highest rate of active substance extraction and the frequency of 37 kHz increased the efficiency more than the frequency of 80 kHz. Using ultrasonic fluid extraction method with the help of ultrasonic waves due to pain Stress, non-pollution and high efficiency of this method will be more cost-effective than other methods.

### References

- [1] M. Alagawany, M.A. El-Hack, M.R. Farag, R. Tiwari, K. Dhama, *Advances in Animal and Veterinary Sciences*, **2015**, 3, 73-84. [[crossref](#)], [[Google Scholar](#)], [[Publisher](#)]

- [2] M. Bagherisadr, *Journal of Engineering in Industrial Research*, **2020**, *1*, 179-185. [[crossref](#)], [[Google Scholar](#)], [[Publisher](#)]
- [3] A. Liazid, M. Schwarz, R.M. Varela, M. Palma, D.A. Guillén, J. Brigui, F.A. Macías, C.G. Barroso, *Food and Bio-products Processing*, **2010**, *88*, 247-252. [[crossref](#)], [[Google Scholar](#)], [[Publisher](#)]
- [4] B. Yang, H. Yang, J. Li, Z. Li, Y. Jiang, *Food Chemistry*, **2011**, *124*, 551-555. [[crossref](#)], [[Google Scholar](#)], [[Publisher](#)]
- [5] G.F. Barbero, A. Liazid, M. Palma, C.G. Barroso, Ultrasound-assisted extraction of capsaicinoids from peppers. *Talanta*. **2008**, *75*, 1332-1337. [[crossref](#)], [[Google Scholar](#)], [[Publisher](#)]
- [6] V. Sivakumar, J.L. Anna, J. Vijayeeswarri, G. Swaminathan, *Ultrasonic Sonochemistry*, **2009**, *16*, 782-789. [[crossref](#)], [[Google Scholar](#)], [[Publisher](#)]
- [7] B.A. Romero, E. Bou-Maroun, J.M. Reparet, J. Blanquet, N. Cayot, *Food Chemistry*, **2010**, *119*, 459-466. [[crossref](#)], [[Google Scholar](#)], [[Publisher](#)]
- [8] M. Amirikoshkeki, *Journal of Engineering in Industrial Research*, **2020**, *1*, 170-178. [[crossref](#)], [[Google Scholar](#)], [[Publisher](#)]
- [9] L. Wang, C.L. Weller, *Trends in Food Science & Technology*, **2006**, *17*, 300-312. [[crossref](#)], [[Google Scholar](#)], [[Publisher](#)]
- [10] D.A.J. Starmans, H.H. Nijhuis, *Trends in Food Science & Technology*, **1996**, *7*, 191-197. [[crossref](#)], [[Google Scholar](#)], [[Publisher](#)]
- [11] E. Riera, Y. Golas, A. Blanco, J.A. Gallego, M. Blasco, A. Mulet, *Ultrasonic Sonochemistry*, **2004**, *11*, 241-244. [[crossref](#)], [[Google Scholar](#)], [[Publisher](#)]
- [12] F. Sahena, I.S.M. Zaidul, S. Jinap, A.A. Karim, K.A. Abbas, N.A.N. Norulaini, A.K.M. Omar, *Journal of Food Engineering*, **2009**, *95*, 240-253. [[crossref](#)], [[Google Scholar](#)], [[Publisher](#)]
- [13] S.C. Chua, C.P. Tan, H. Mirhosseini, O.M. Lai, K. Long, B.S. Baharin, *Journal of Food Engineering*, **2009**, *92*, 403-409. [[crossref](#)], [[Google Scholar](#)], [[Publisher](#)]
- [14] Y.Q. Ma, J.C. Chen, D.H. Liu, X.Q. Ye, *Ultrasonic son chemistry*, **2009**, *16*, 57-62. [[crossref](#)], [[Google Scholar](#)], [[Publisher](#)]
- [15] B. Karki, B.P. Lamsal, S. Jung, J.H. van Leeuwen, A.L. Pometto III, D. Grewell, S.K. Khanal, *Journal of Food Engineering*, **2010**, *96*, 270-278. [[crossref](#)], [[Google Scholar](#)], [[Publisher](#)]
- [16] S. Naguleswaran, T. Vasanthan, *Food chemistry*, **2010**, *118*, 627-633. [[crossref](#)], [[Google Scholar](#)], [[Publisher](#)]
- [17] H.F. Zhang, X.H. Yang, L.D. Zhao, Y. Wang, *Innovative food science & emerging technologies*, **2009**, *10*, 54-60. [[crossref](#)], [[Google Scholar](#)], [[Publisher](#)]
- [18] C. Da Porto, D. Decorti, *Ultrasonic sonochemistry*, **2009**, *16*, 795-799. [[crossref](#)], [[Google Scholar](#)], [[Publisher](#)]
- [19] B. Barmasi, *Journal of Engineering in Industrial Research*, **2020**, *1*, 161-169. [[crossref](#)], [[Google Scholar](#)], [[Publisher](#)]
- [20] S. Veillet, V. Tomao, F. Chemat, *Food Chemistry*, **2010**, *123*, 905-911. [[crossref](#)], [[Google Scholar](#)], [[Publisher](#)]
- [21] J.M. Roldán-Gutiérrez, J. Ruiz-Jiménez, M.L. De Castro. *Talanta*, **2008**, *75*, 1990-1996. [[crossref](#)], [[Google Scholar](#)], [[Publisher](#)]
- [22] Alireza Bozorgian, *Journal of Engineering in Industrial Research*, **2020**, *1*, 1-18. [[crossref](#)], [[Google Scholar](#)], [[Publisher](#)]
- [23] F. Rebout, *Journal of Engineering in Industrial Research*, **2020**, *1*, 19-37 [[crossref](#)], [[Google Scholar](#)], [[Publisher](#)]
- [24] K.L. Han, *Journal of Engineering in Industrial Research*, **2020**, *1*, 38-50. [[crossref](#)], [[Google Scholar](#)], [[Publisher](#)]
- [25] F. Gharekhani Kasa, *Journal of Engineering in Industrial Research*, **2020**, *1*, 51-74. [[crossref](#)], [[Google Scholar](#)], [[Publisher](#)]
- [26] M. Zbuzant, *Journal of Engineering in Industrial Research*, **2020**, *1*, 75-81. [[crossref](#)], [[Google Scholar](#)], [[Publisher](#)]
- [27] M. Amirikoshkeki, *Journal of Engineering in Industrial Research*, **2020**, *1*, 82-90. [[crossref](#)], [[Google Scholar](#)], [[Publisher](#)]
- [28] M. Amini Sadrodin, *Journal of Engineering in Industrial Research*, **2020**, *1*, 91-98. [[crossref](#)], [[Google Scholar](#)], [[Publisher](#)]
- [29] E. Amouzad Mahdiraji; M. Sedghi Amiri, *Journal of Engineering in Industrial Research*, **2020**, *1*, 111-122. [[crossref](#)], [[Google Scholar](#)], [[Publisher](#)]

- [30] K.L. Han, *Journal of Engineering in Industrial Research*, **2020**, *1*, 123-133. [[crossref](#)], [[Google Scholar](#)], [[Publisher](#)]
- [31] A. Ahmad, A.S. Reyazi, *Journal of Engineering in Industrial Research*, **2020**, *1*, 134-160. [[crossref](#)], [[Google Scholar](#)], [[Publisher](#)]
- [32] A. Susanabadi, S. Etemadi, M.S. Sadri, B. Mahmoodiyeh, H. Taleby, M.M. Fard, *Annals of the Romanian Society for Cell Biology*, **2021**, *25*, 2875-2887. [[crossref](#)], [[Google Scholar](#)], [[Publisher](#)]
- [33] K. Ghajarzadeh, M.M. Fard, H. Alizadeh Otaghvar, S.H.R. Faiz, A. Dabbagh, M. Mohseni, S.S. Kashani, A.M.M. Fard, M.R. Alebouyeh, *Annals of the Romanian Society for Cell Biology*, **2021**, *25*, 2457-2465. [[crossref](#)], [[Google Scholar](#)], [[Publisher](#)]
- [34] K. Ghajarzadeh, M.M. Fard, M.R. Alebouyeh, H. Alizadeh Otaghvar, A. Dabbagh, M. Mohseni, S.S. Kashani, A.M.M. Fard, S.H.R. Faiz, *Annals of the Romanian Society for Cell Biology*, **2021**, *25*, 2466-2484. [[crossref](#)], [[Google Scholar](#)], [[Publisher](#)]
- [35] K. Ghajarzadeh, M.M. Fard, H. Alizadeh Otaghvar, S.H.R. Faiz, A. Dabbagh, M. Mohseni, S.S. Kashani, A.M.M. Fard, M.R. Alebouyeh, *Annals of the Romanian Society for Cell Biology*, **2021**, *25*, 2449-2456. [[crossref](#)], [[Google Scholar](#)], [[Publisher](#)]
- [36] F.E. Sadr, Z. Abadi, N.E. Sadr, M.M. Fard, *Annals of the Romanian Society for Cell Biology*, **2021**, *25*, 6839-6852. [[crossref](#)], [[Google Scholar](#)], [[Publisher](#)]
- [37] S. Sangy, F. Miryousefiata, A. Bahaoddini, H. Dimiati, *Budapest International Research in Exact Sciences (BirEx) Journal*, **2020**, *2(4)*, 458-466. [[crossref](#)], [[Google Scholar](#)], [[Publisher](#)]
- [38] F. Miryousefiata, S Sangy, *Journal of Medicinal and Chemical Sciences*, **2021**, *4*, 60-74. [[crossref](#)], [[Google Scholar](#)], [[Publisher](#)]
- [39] F. Zare Kazemabadi, A. Heydarinasab, A. Akbarzadeh, M. Ardjmand, *Artificial cells, nanomedicine, and biotechnology*, **2019**, *47*, 3222-3230. [[crossref](#)], [[Google Scholar](#)], [[Publisher](#)]
- [40] F. Zare Kazemabadi, A. Heydarinasab, A. Akbarzadehkhiyavi, M. Ardjmand, *Chemical Methodologies*, **2021**, *5*, 135-152. [[crossref](#)], [[Google Scholar](#)], [[Publisher](#)]
- [41] S.M.S. Mirnezami, F. Zare Kazemabadi, A. Heydarinasab, *Progress in Chemical and Biochemical Research*, **2021**, *4*, 191-206. [[crossref](#)], [[Google Scholar](#)], [[Publisher](#)]